

SYM	CHANGES	DATE	BY
-----	---------	------	----

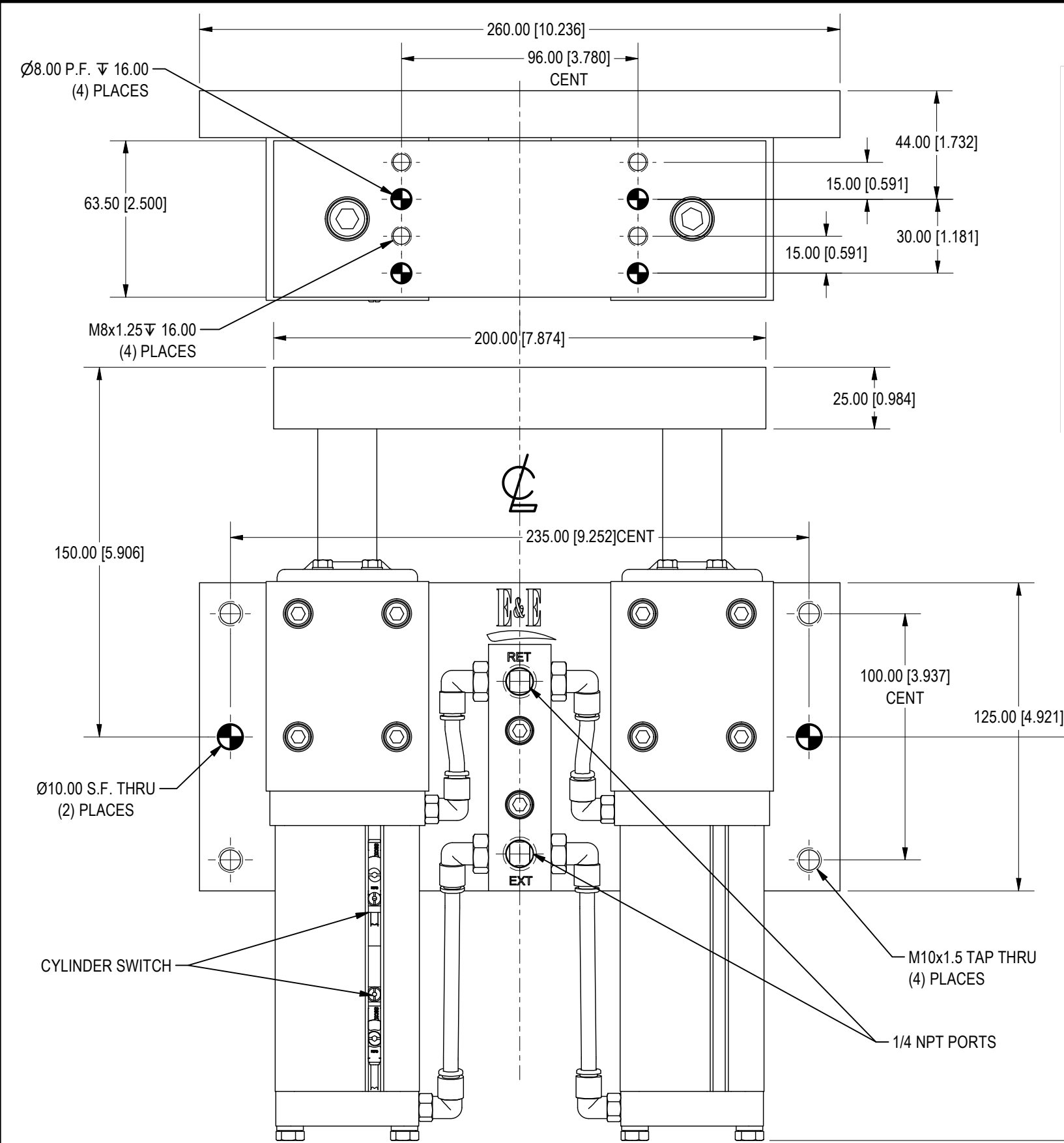

ORDERING INFORMATION

DF24 - [] [] [] **N S O C** [] [] **O**

Stroke
025, 050, 075, 100, 125 & 150mm

Actuator
N Pneumatic - NPT Ports

Switch
S Sick (Standard) Weld Immune

Switch Position
E S01 Ext Pos
R S01 Ret Pos

Switch Type
C Cylinder Switch

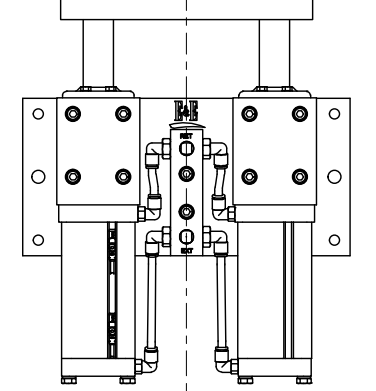
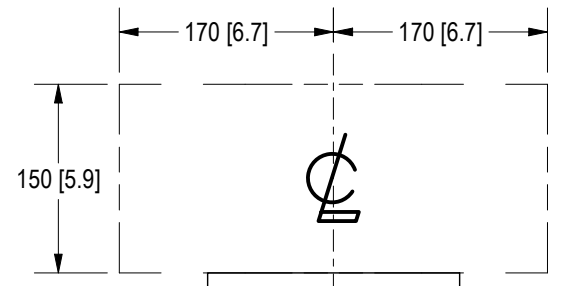
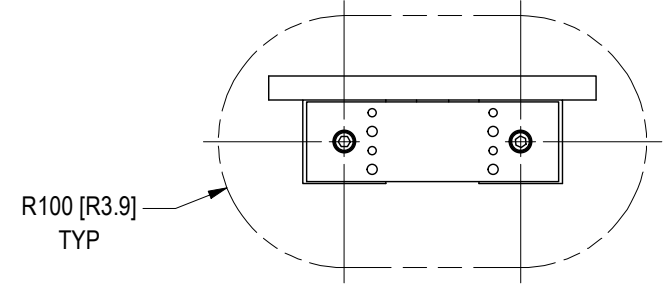
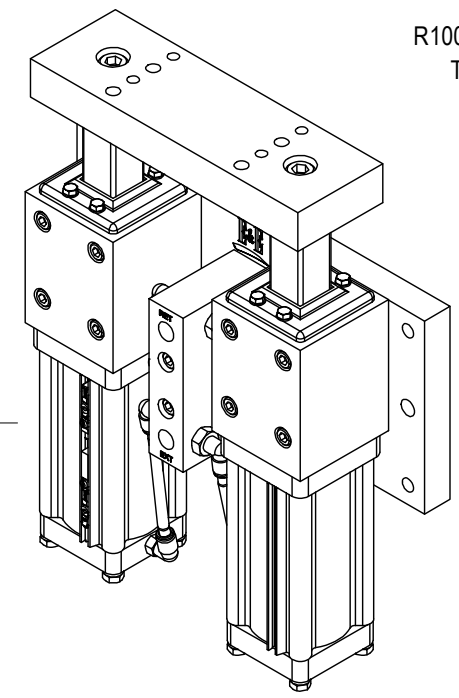

WORK ENVELOPE

164.0 [6.45] FOR 25,50 & 75 STROKE
279.0 [10.98] FOR 100, 125 & 150 STROKE

OPERATING PRESSURE - MIN 60psi = 364lbf [165.1kgf] EXT FORCE - 338lbf [153.3kgf] RETRACT FORCE
MAX 120psi = 724lbf [328.3kgf] EXT FORCE - 677.0lbf [307.0kgf] RETRACT FORCE

WEIGHTS =
30.0lbs for 25mm, 50mm & 75mm Strokes
34.0lbs for 100mm, 125mm & 150mm StrokeS

 7200 MILLER DR. WARREN, MI 48092 EE-CP.COM	NOTICE: THIS DRAWING IS PROPERTY OF E&E CUSTOM PRODUCTS INCLUDING THE PRINCIPLES OF THE DESIGN INVOLVED, AND IS SUBMITTED WITH AGREEMENT THAT IT IS NOT TO BE REPRODUCED, COPIED, OR LOANED, IN PART OR WHOLE, ACCEPTANCE OF THIS DRAWING WILL BE CONSTRUED AS AN AGREEMENT TO THE ABOVE		
	TITLE DUAL ASP24 SERIES SHOT PIN		
	PART NO.		
	DRAWN BY: EE	CHK'D BY: EC	APPR'D BY: MH
	DATE: 3/21/2023	DATE: 3/21/2023	DATE: 3/21/2023
SCALE: 1/2	DWG. NO. DF24-TEMPLATE-GESTAMP		
SHT 1 OF 1			