

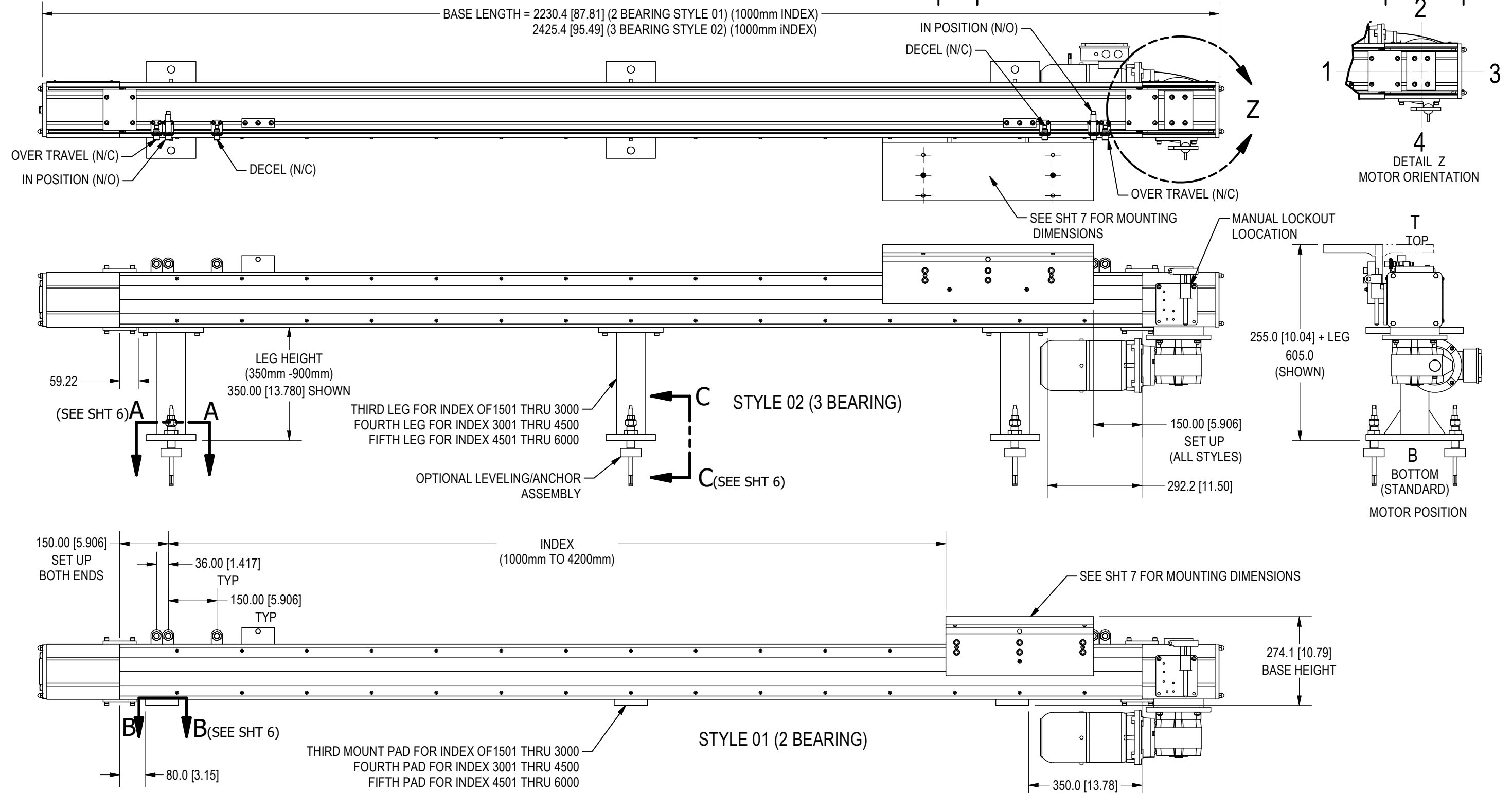

SYM	CHANGES	DATE	BY
		2	



SINGLE EXTRUSION BELT - STYLES 01 & 02

<p>E &amp; E CUSTOM PRODUCTS</p> <p>7200 MILLER DR. WARREN, MI 48092 EE-CP.COM</p>	<p>NOTICE: THIS DRAWING IS PROPERTY OF E&amp;E CUSTOM PRODUCTS INCLUDING THE PRINCIPLES OF THE DESIGN INVOLVED, AND IS SUBMITTED WITH AGREEMENT THAT IT IS NOT TO BE REPRODUCED, COPIED, OR LOANED, IN PART OR WHOLE, ACCEPTANCE OF THIS DRAWING WILL BE CONSTRUED AS AN AGREEMENT TO THE ABOVE</p>		
	<p>TITLE PART TRANSFER BELT DRIVE EXTRUSION SLIDE</p>		
	<p>PART NO.</p>		
	<p>DRAWN BY: EE</p>	<p>CHK'D BY: EC</p>	<p>APPR'D BY: MH</p>
	<p>DATE: 3/27/2023</p>	<p>DATE: 3/27/2023</p>	<p>DATE: 3/27/2023</p>
<p>SCALE: 1/12</p>	<p>DWG. NO. PTS_BELT TEMPLATE-GESTAMP</p>		
<p>SHT 2 OF 9</p>			

SYM	CHANGES	DATE	BY
-----	---------	------	----

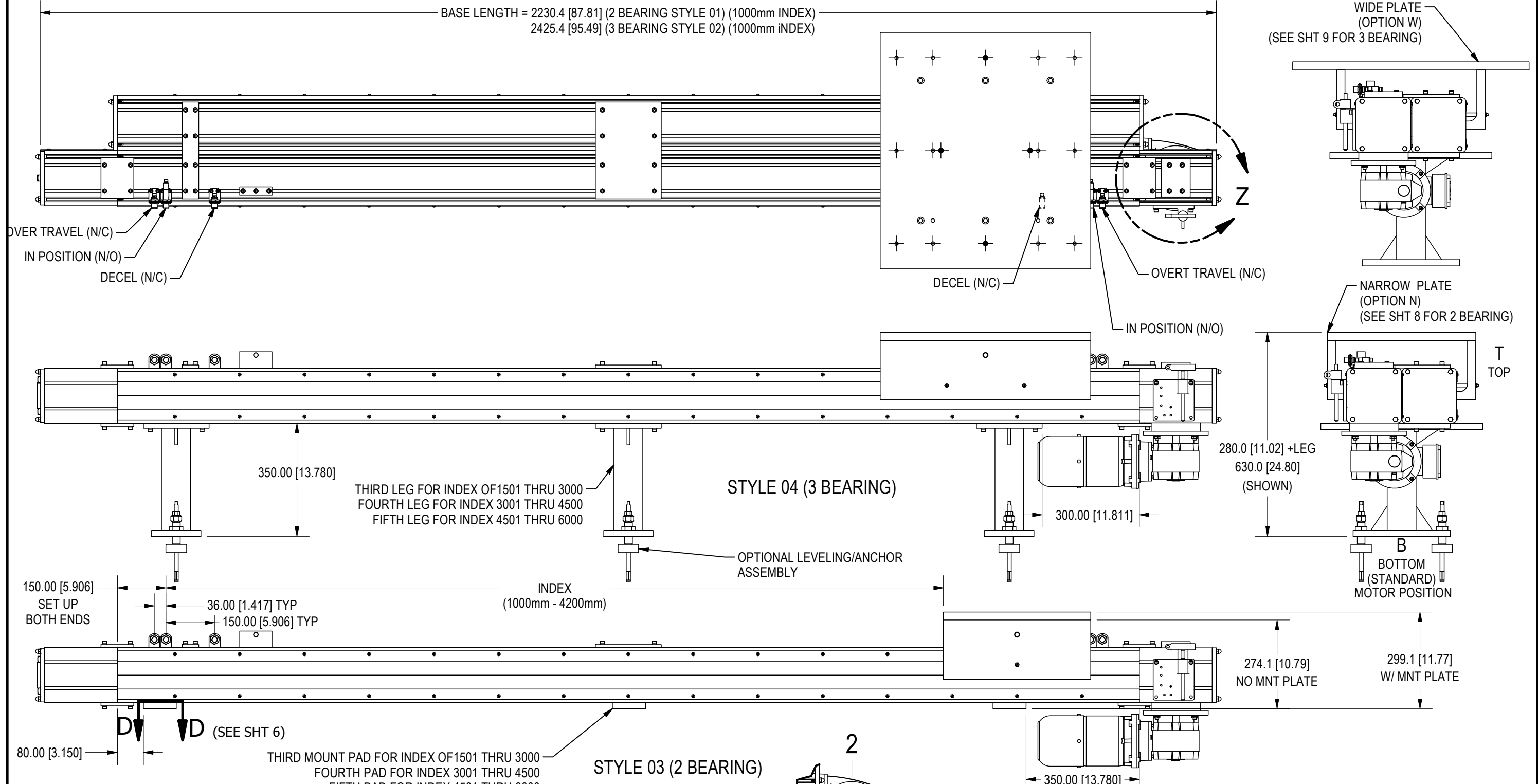

# DOUBLE EXTRUSION BELT - STYLES 03 & 04

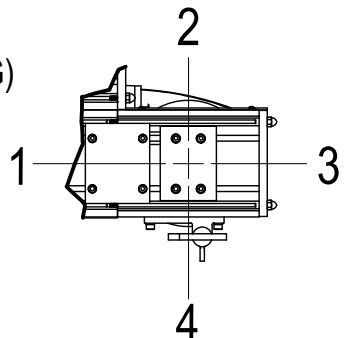

DETAIL Z  
 MOTOR ORIENTATION

<p>E &amp; E          CUSTOM PRODUCTS</p>	NOTICE: THIS DRAWING IS PROPERTY OF E&E CUSTOM PRODUCTS INCLUDING THE PRINCIPLES OF THE DESIGN INVOLVED, AND IS SUBMITTED WITH AGREEMENT THAT IT IS NOT TO BE REPRODUCED, COPIED, OR LOANED, IN PART OR WHOLE, ACCEPTANCE OF THIS DRAWING WILL BE CONSTRUED AS AN AGREEMENT TO THE ABOVE		
	TITLE PART TRANSFER BELT DRIVE EXTRUSION SLIDE		
	PART NO.		
	DRAWN BY: EE	CHK'D BY: EC	APPR'D BY: MH
7200 MILLER DR. WARREN, MI 48092 EE-CP.COM	DATE: 3/27/2023	DATE: 3/27/2023	DATE: 3/27/2023
	SCALE: 1/12	DWG. NO. PTS_BELT TEMPLATE-GESTAMP	
	SHT 3 OF 9		

SYM	CHANGES	DATE	BY
-----	---------	------	----

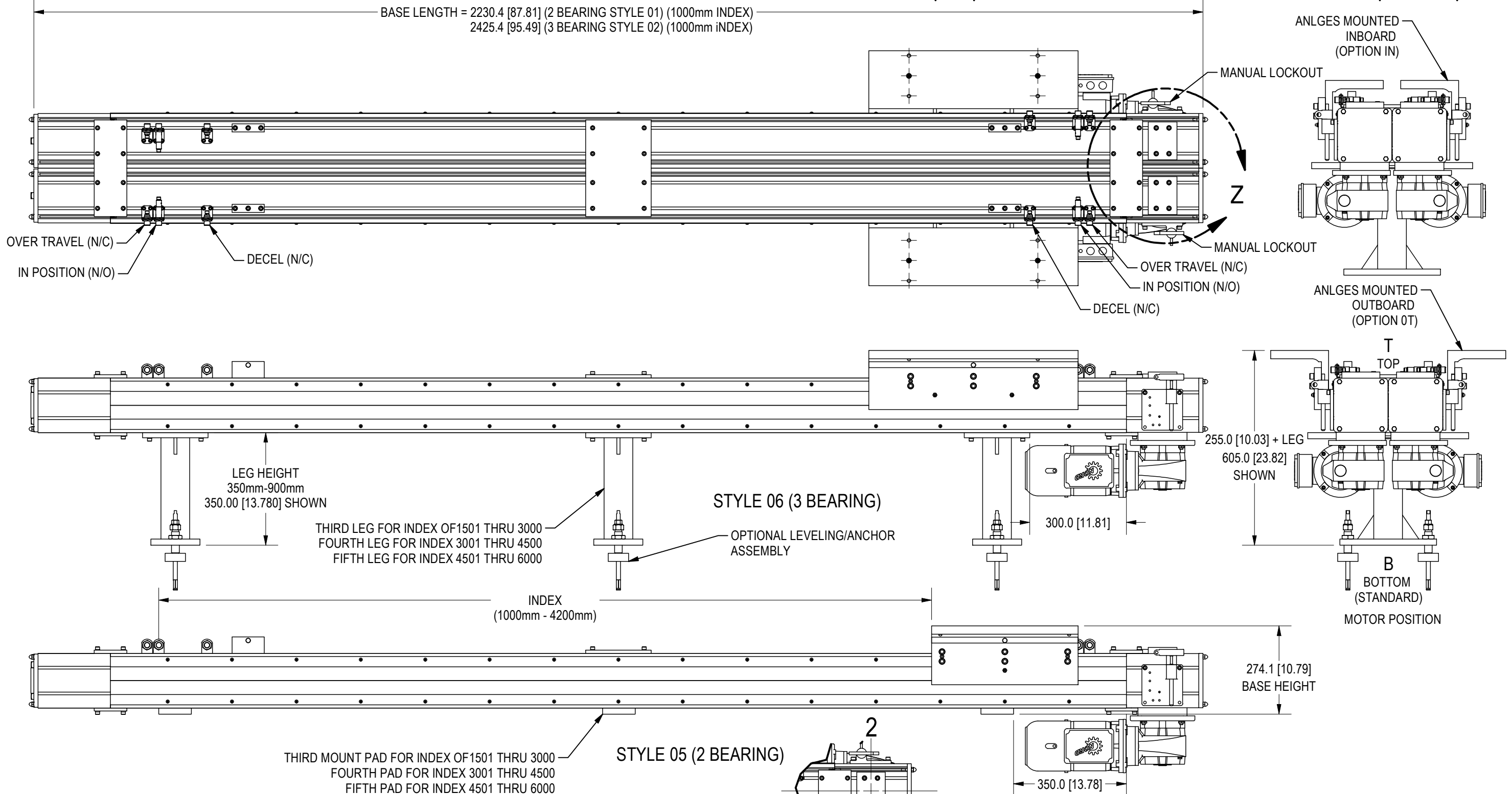

# DOUBLE INDEPENDENT EXTRUSION BELT - STYLES 05 & 06

MOTOR NOTE:  
IF MOTOR POSITIONS 2 OR 4 ARE SPECIFIED, MOTORS WILL BE SHIPPED IN 2 & 4 POSITION

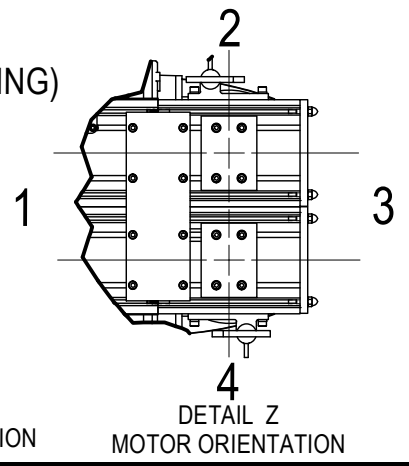

<p>E &amp; E CUSTOM PRODUCTS</p> <p>7200 MILLER DR. WARREN, MI 48092 EE-CP.COM</p>	<p>NOTICE: THIS DRAWING IS PROPERTY OF E&amp;E CUSTOM PRODUCTS INCLUDING THE PRINCIPLES OF THE DESIGN INVOLVED, AND IS SUBMITTED WITH AGREEMENT THAT IT IS NOT TO BE REPRODUCED, COPIED, OR LOANED, IN PART OR WHOLE, ACCEPTANCE OF THIS DRAWING WILL BE CONSTRUED AS AN AGREEMENT TO THE ABOVE</p>		
	<p>TITLE PART TRANSFER BELT DRIVE EXTRUSION SLIDE</p>		
	<p>PART NO.</p>		
	<p>DRAWN BY: EE</p> <p>DATE: 3/27/2023</p> <p>SCALE: 1/12</p> <p>SHT 4 OF 9</p>	<p>CHK'D BY: EC</p> <p>DATE: 3/27/2023</p> <p>DWG. NO. PTS_BELT TEMPLATE-GESTAMP</p>	<p>APPR'D BY: MH</p> <p>DATE: 3/27/2023</p>

SYM	CHANGES	DATE	BY
-----	---------	------	----

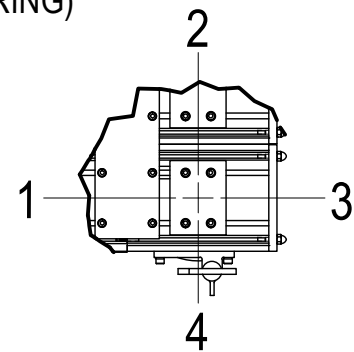
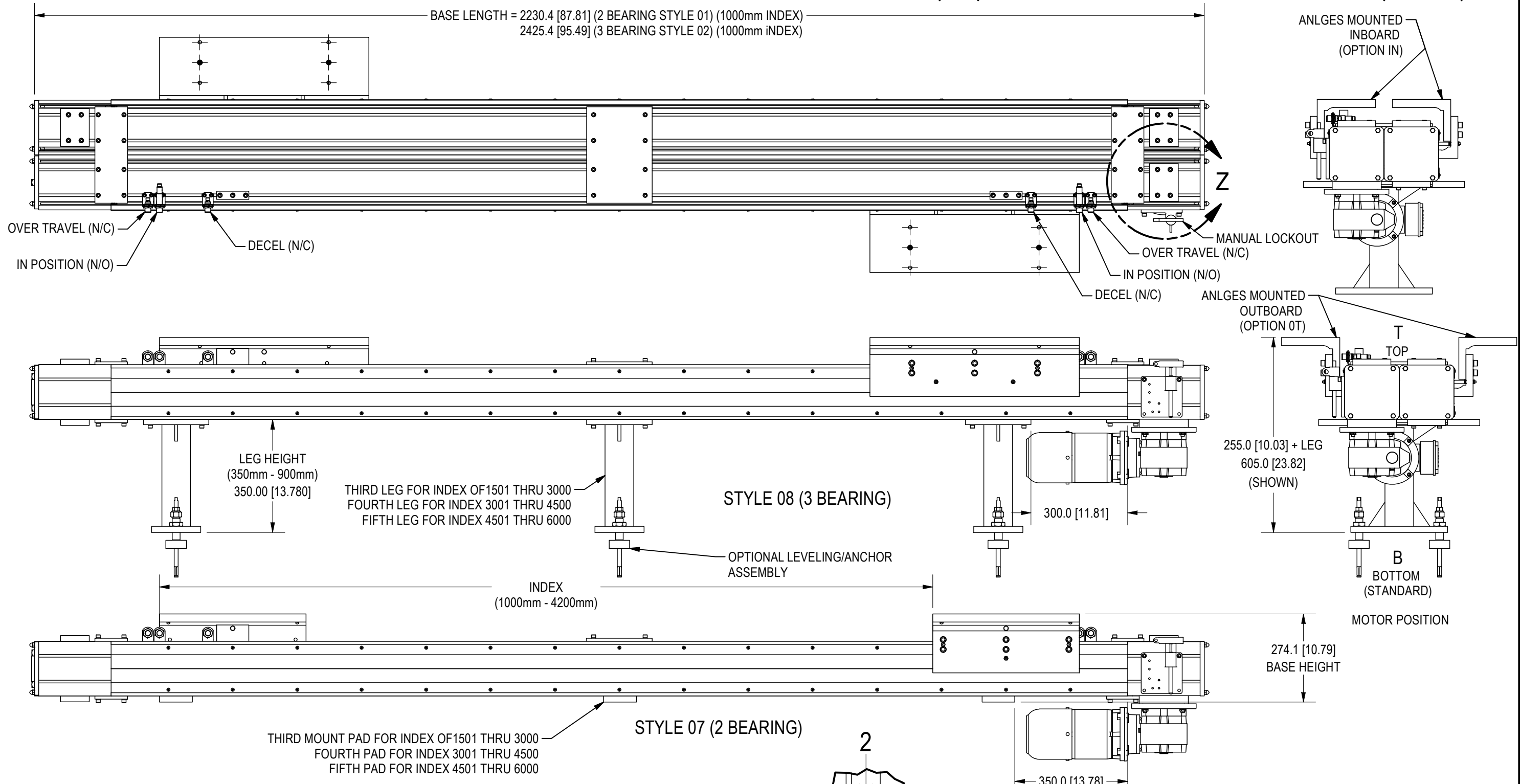

DETAIL Z  
MOTOR ORIENTATION

PUSH / PULL EXTRUSION BELT - STYLES 07 & 08

<p>E &amp; E CUSTOM PRODUCTS</p>	<p>NOTICE: THIS DRAWING IS PROPERTY OF E&amp;E CUSTOM PRODUCTS INCLUDING THE PRINCIPLES OF THE DESIGN INVOLVED, AND IS SUBMITTED WITH AGREEMENT THAT IT IS NOT TO BE REPRODUCED, COPIED, OR LOANED, IN PART OR WHOLE, ACCEPTANCE OF THIS DRAWING WILL BE CONSTRUED AS AN AGREEMENT TO THE ABOVE</p>		
	<p>TITLE PART TRANSFER BELT DRIVE EXTRUSION SLIDE</p>		
	<p>PART NO.</p>		
	<p>DRAWN BY: EE</p>	<p>CHK'D BY: EC</p>	<p>APPR'D BY: MH</p>
<p>7200 MILLER DR. WARREN, MI 48092 EE-CP.COM</p>	<p>DATE: 3/27/2023</p>	<p>DATE: 3/27/2023</p>	<p>DATE: 3/27/2023</p>
<p>SCALE: 1/12</p>	<p>DWG. NO. PTS_BELT TEMPLATE-GESTAMP</p>		
<p>SHT 5 OF 9</p>			

SYM	CHANGES	DATE	BY
-----	---------	------	----

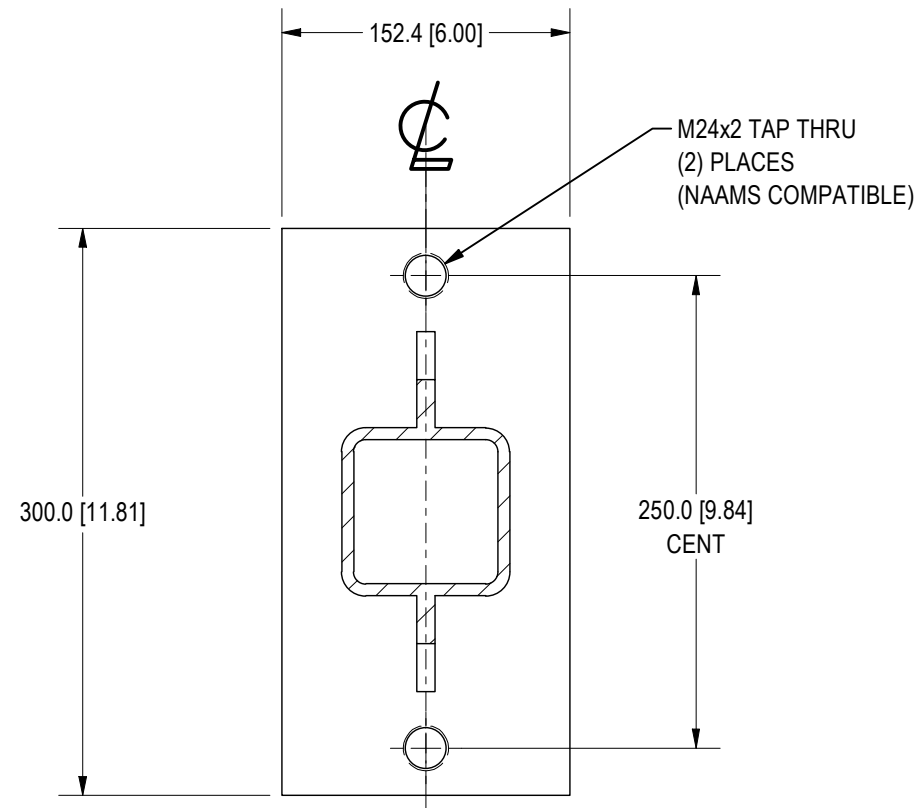

**SECTION A-A**  
LEG OPTION  
ALL STYLES

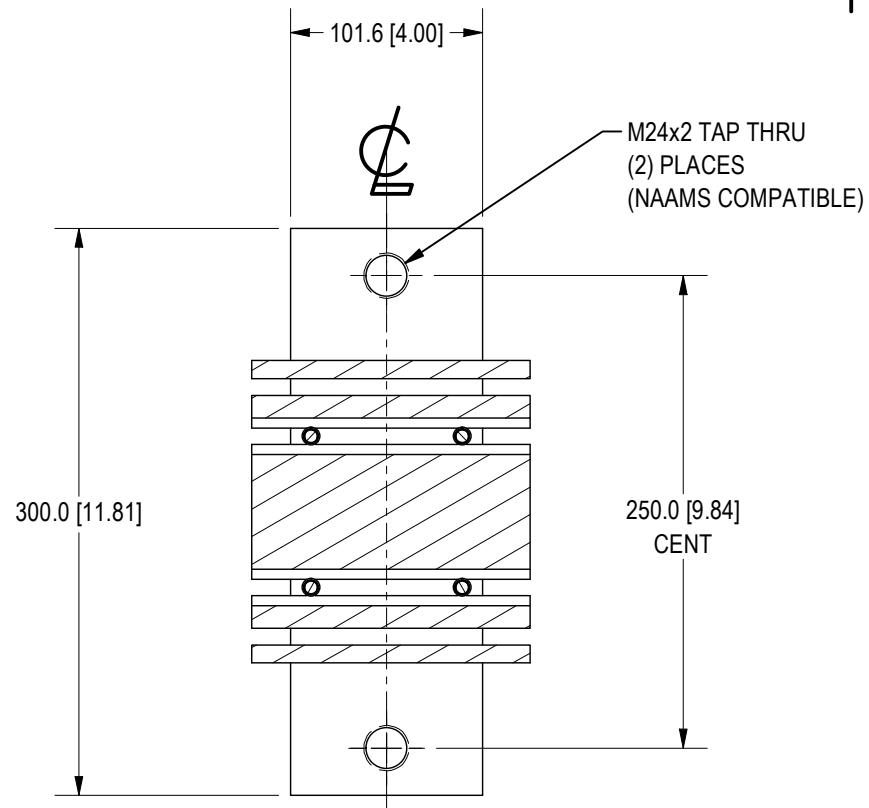

**SECTION B-B**  
SINGLE EXT MOUNT PAD  
STYLES 01 & 02

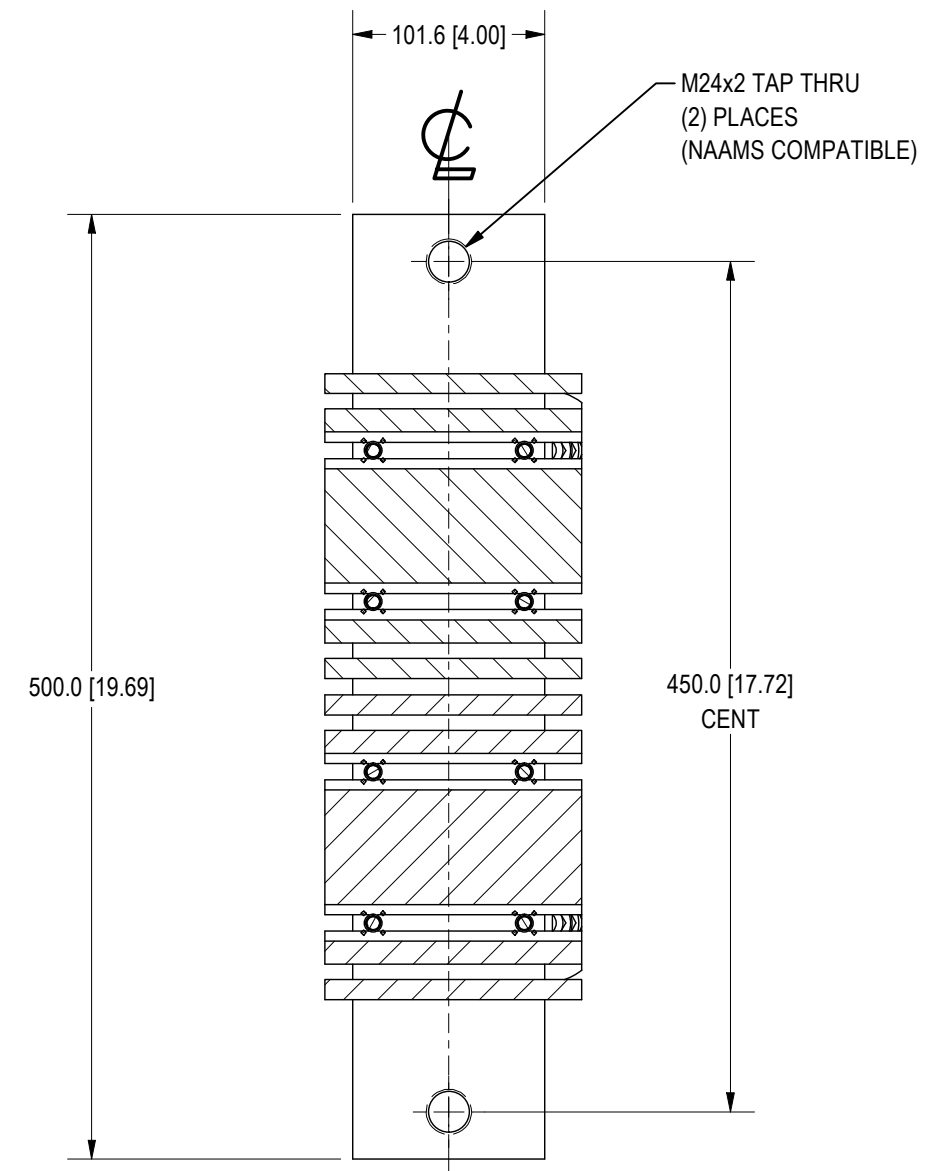

**SECTION D-D**  
DOUBLE, DOUBLE INDEP AND PUSH / PULL MOUNT PAD  
STYLES 03 THRU 08

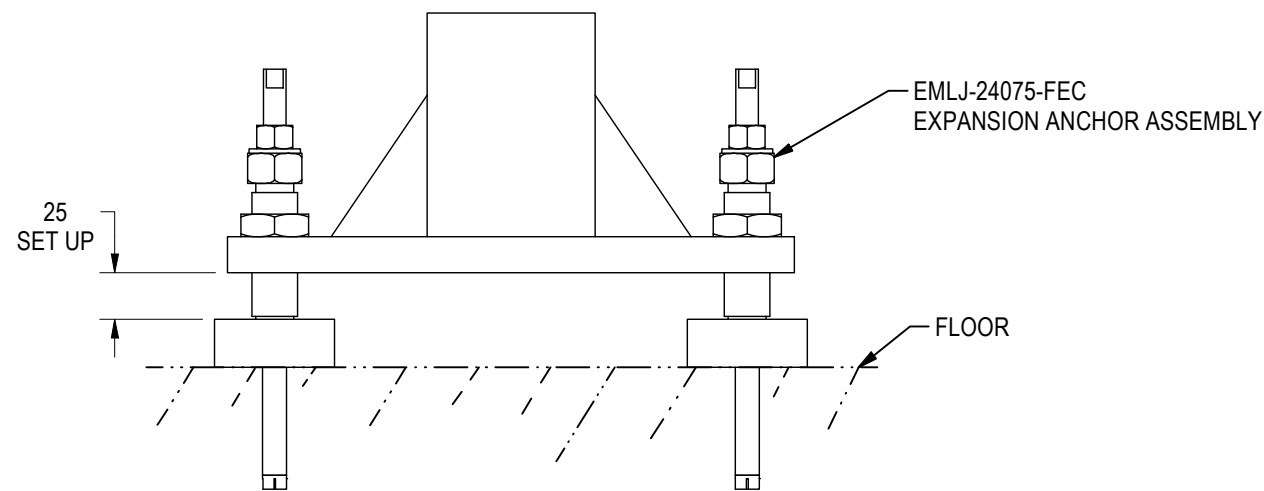

**SECTION C-C**  
LEG OPTION WITH LEVELING  
ALL STYLES

**LEG AND MOUNTING PLATE OPTIONS**

 7200 MILLER DR. WARREN, MI 48092 EE-CP.COM	NOTICE: THIS DRAWING IS PROPERTY OF E&E CUSTOM PRODUCTS INCLUDING THE PRINCIPLES OF THE DESIGN INVOLVED, AND IS SUBMITTED WITH AGREEMENT THAT IT IS NOT TO BE REPRODUCED, COPIED, OR LOANED, IN PART OR WHOLE, ACCEPTANCE OF THIS DRAWING WILL BE CONSTRUED AS AN AGREEMENT TO THE ABOVE		
	TITLE PART TRANSFER BELT DRIVE EXTRUSION SLIDE		
	PART NO.		
	DRAWN BY: EE	CHK'D BY: EC	APPR'D BY: MH
	DATE: 3/27/2023	DATE: 3/27/2023	DATE: 3/27/2023
SCALE: 1/4	DWG. NO. PTS_BELT TEMPLATE-GESTAMP		
SHT 6 OF 9			

SYM	CHANGES	DATE	BY

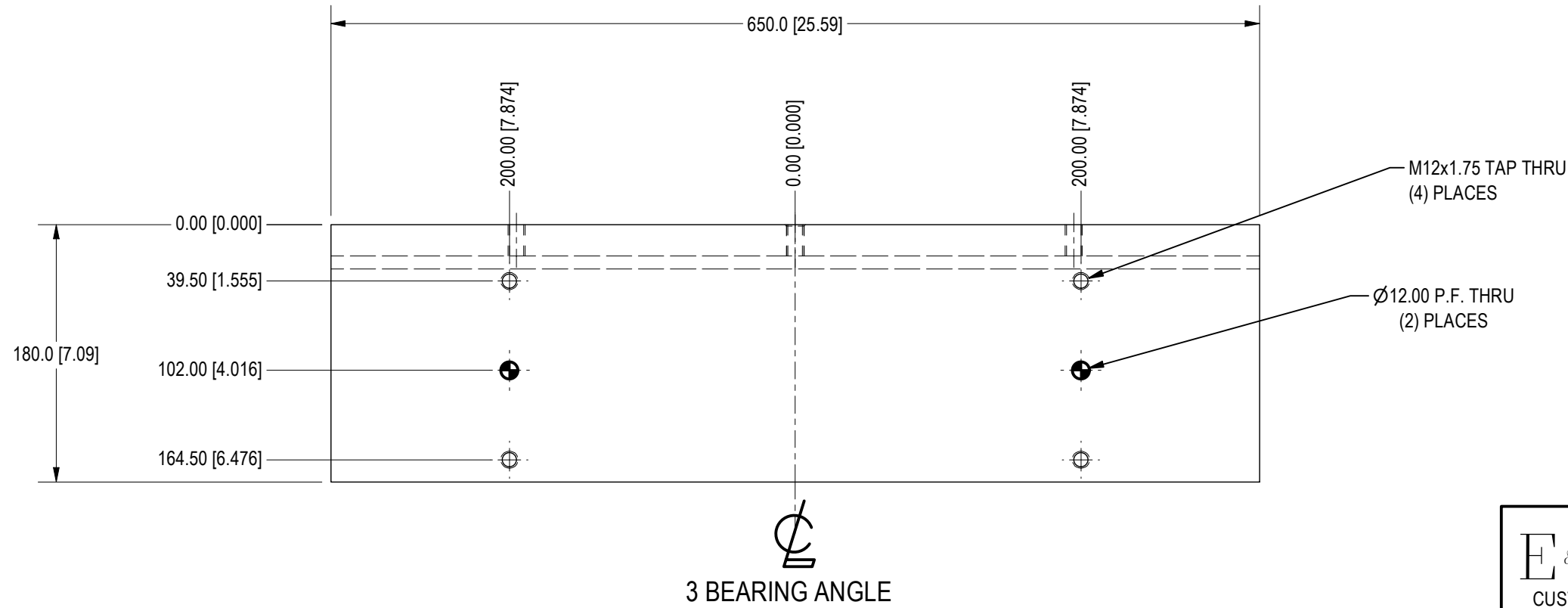
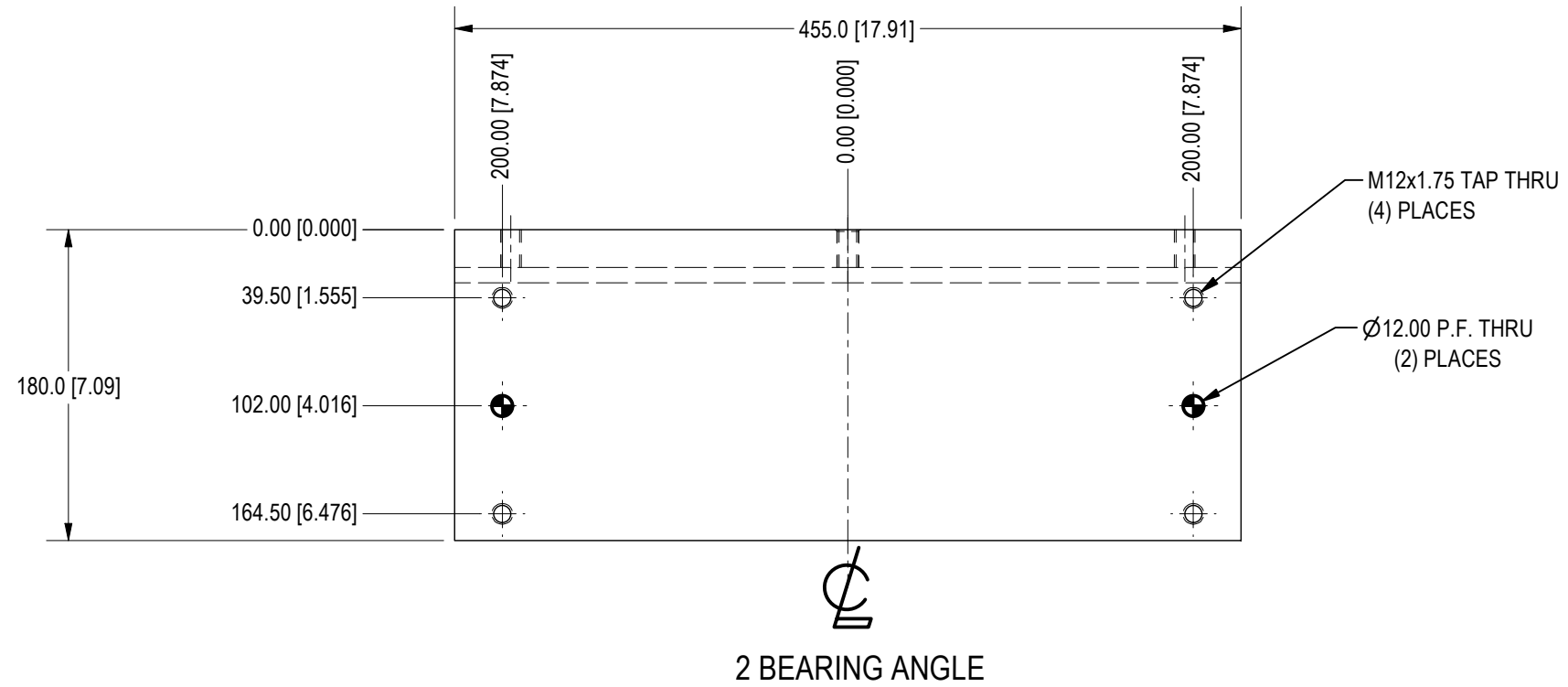

ANGLE MOUNTING PATTERNS STYLES  
01, 02, 05, 06, 07 AND 08

<p>7200 MILLER DR. WARREN, MI 48092 EE-CP.COM</p>	<small>NOTICE: THIS DRAWING IS PROPERTY OF E&amp;E CUSTOM PRODUCTS INCLUDING THE PRINCIPLES OF THE DESIGN INVOLVED, AND IS SUBMITTED WITH AGREEMENT THAT IT IS NOT TO BE REPRODUCED, COPIED, OR LOANED, IN PART OR WHOLE, ACCEPTANCE OF THIS DRAWING WILL BE CONSTRUED AS AN AGREEMENT TO THE ABOVE</small>		
	TITLE PART TRANSFER BELT DRIVE EXTRUSION SLIDE		
	PART NO.		
	DRAWN BY: EE	CHK'D BY: EC	APPR'D BY: MH
	DATE: 3/27/2023	DATE: 3/27/2023	DATE: 3/27/2023
SCALE: 1/4	DWG. NO. PTS_BELT TEMPLATE-GESTAMP		
SHT 7 OF 9			

SYM	CHANGES	DATE	BY

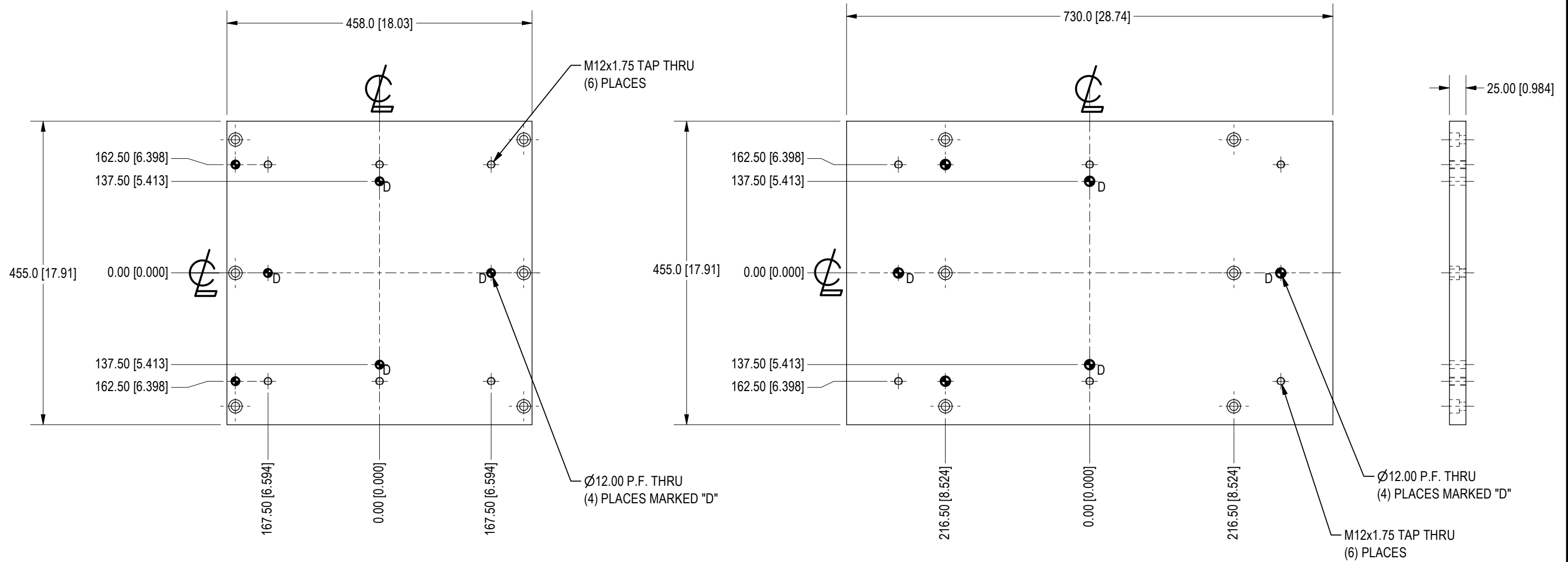

2 BEARING NARROW MOUNTING PLATE

2 BEARING WIDE MOUNTING PLATE

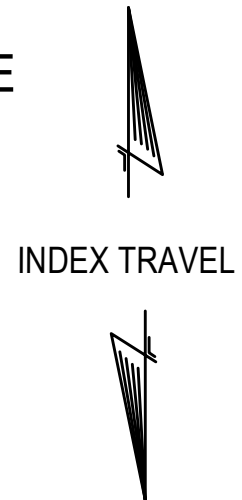

STYLES 03 AND 04 ONLY

<p>7200 MILLER DR. WARREN, MI 48092 EE-CP.COM</p>	<small>NOTICE: THIS DRAWING IS PROPERTY OF E&amp;E CUSTOM PRODUCTS INCLUDING THE PRINCIPLES OF THE DESIGN INVOLVED, AND IS SUBMITTED WITH AGREEMENT THAT IT IS NOT TO BE REPRODUCED, COPIED, OR LOANED, IN PART OR WHOLE, ACCEPTANCE OF THIS DRAWING WILL BE CONSTRUED AS AN AGREEMENT TO THE ABOVE</small>		
	TITLE PART TRANSFER BELT DRIVE EXTRUSION SLIDE		
	PART NO.		
	DRAWN BY: EE	CHK'D BY: EC	APPR'D BY: MH
	DATE: 3/27/2023	DATE: 3/27/2023	DATE: 3/27/2023
SCALE: 1/6	DWG. NO. PTS_BELT TEMPLATE-GESTAMP		
SHT 8 OF 9			



SYM	CHANGES	DATE	BY

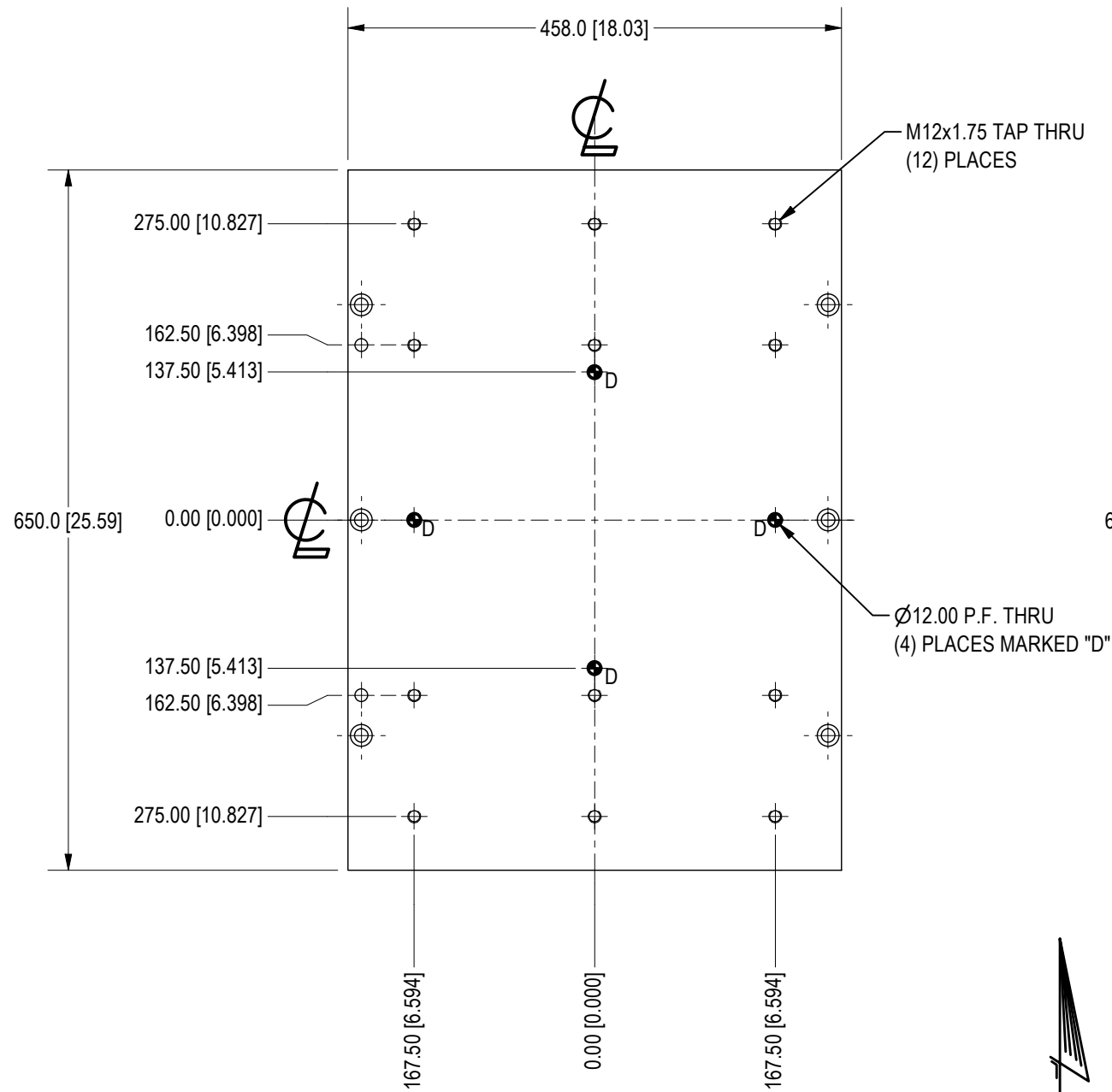

3 BEARING NARROW MOUNTING PLATE

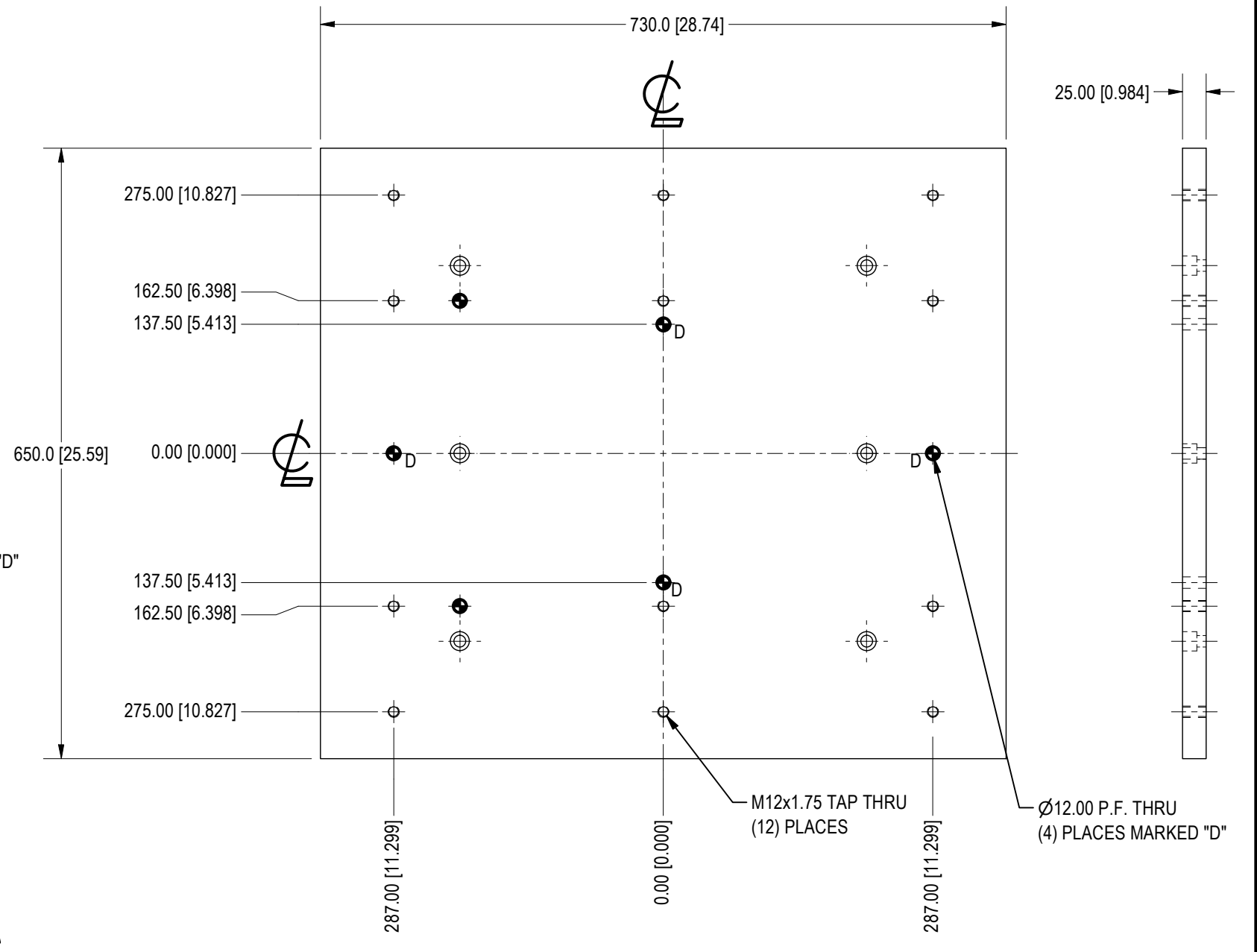

3 BEARING WIDE MOUNTING PLATE



STYLES 03 AND 04 ONLY

<p>7200 MILLER DR. WARREN, MI 48092 EE-CP.COM</p>	<p>NOTICE: THIS DRAWING IS PROPERTY OF E&amp;E CUSTOM PRODUCTS INCLUDING THE PRINCIPLES OF THE DESIGN INVOLVED, AND IS SUBMITTED WITH AGREEMENT THAT IT IS NOT TO BE REPRODUCED, COPIED, OR LOANED, IN PART OR WHOLE, ACCEPTANCE OF THIS DRAWING WILL BE CONSTRUED AS AN AGREEMENT TO THE ABOVE</p>		
	<p>TITLE PART TRANSFER BELT DRIVE EXTRUSION SLIDE</p>		
	<p>PART NO.</p>		
	<p>DRAWN BY: EE</p>	<p>CHK'D BY: EC</p>	<p>APPR'D BY: MH</p>
<p>DATE: 3/27/2023</p>	<p>DATE: 3/27/2023</p>	<p>DATE: 3/27/2023</p>	
<p>SCALE: 1/6</p>	<p>DWG. NO. PTS_BELT TEMPLATE-GESTAMP</p>		
<p>SHT 9 OF 9</p>			