

SWITCHES ARE ALWAYS 90° FROM PORTS

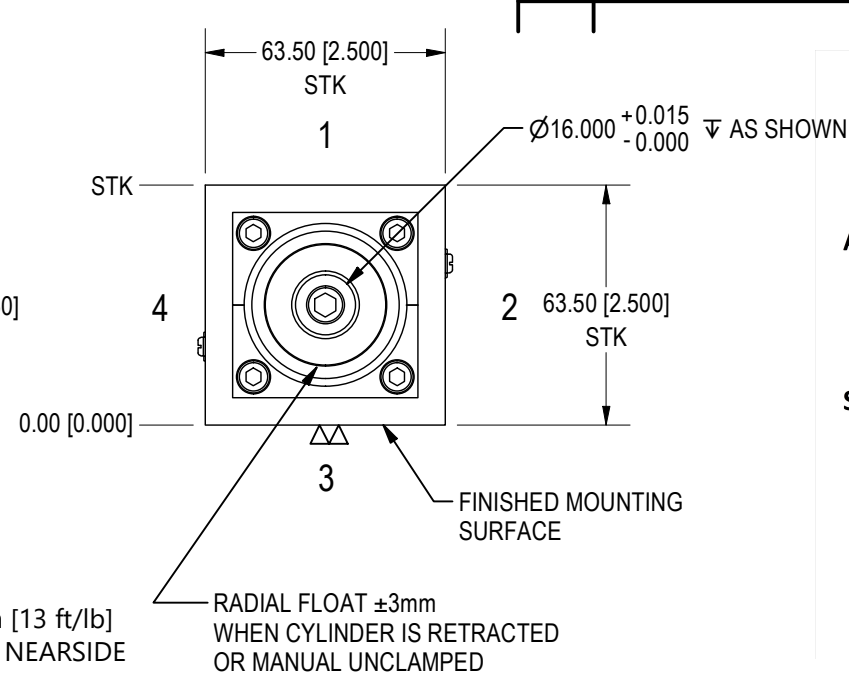

### ORDERING INFORMATION

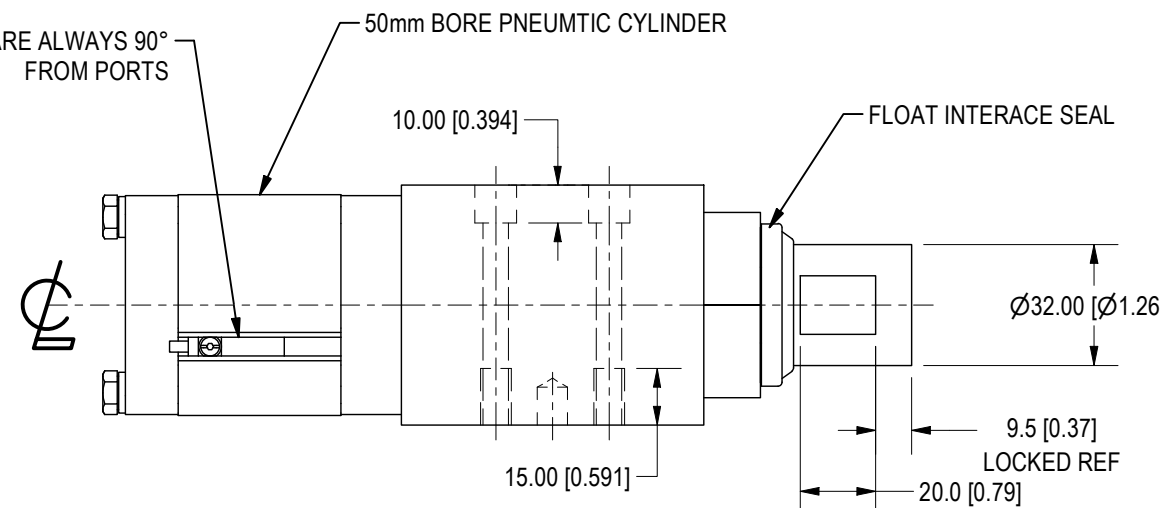
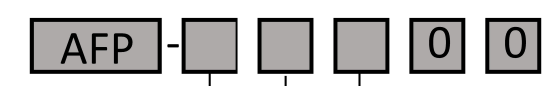

- Actuator**
- N NPT Ports
  - G G Ports
  - M Manual
- Switch**
- E Effector (Weld Immune)
  - B Balluff
  - T Turck
  - S Sick (Standard) Weld Immune
  - O Manual
- Port or Handle Position**
- 1 Position (Shown)
  - 2 Position
  - 3 Position
  - 4 Position

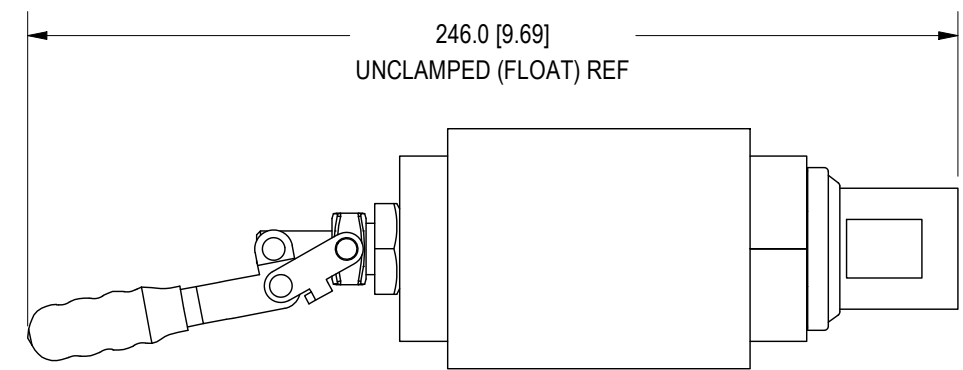
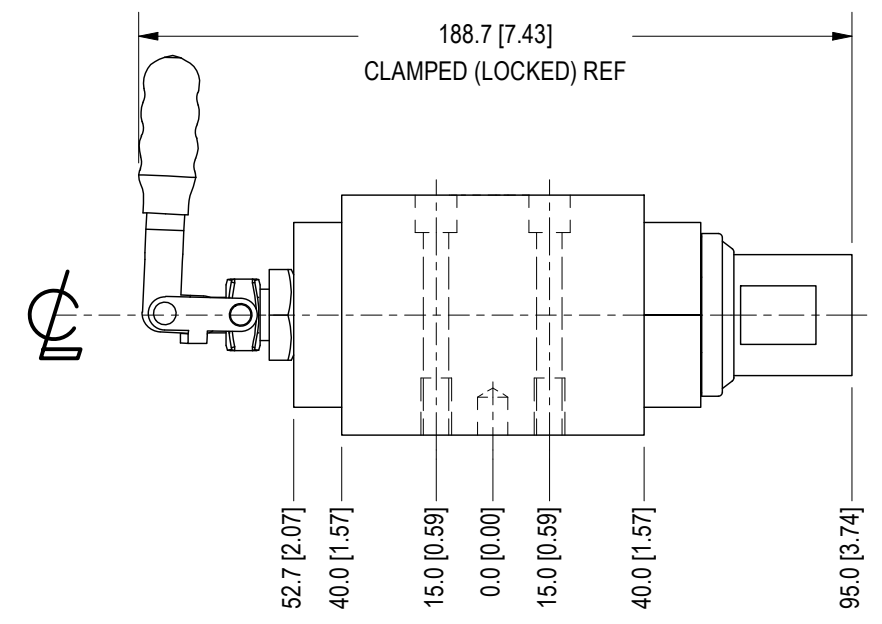
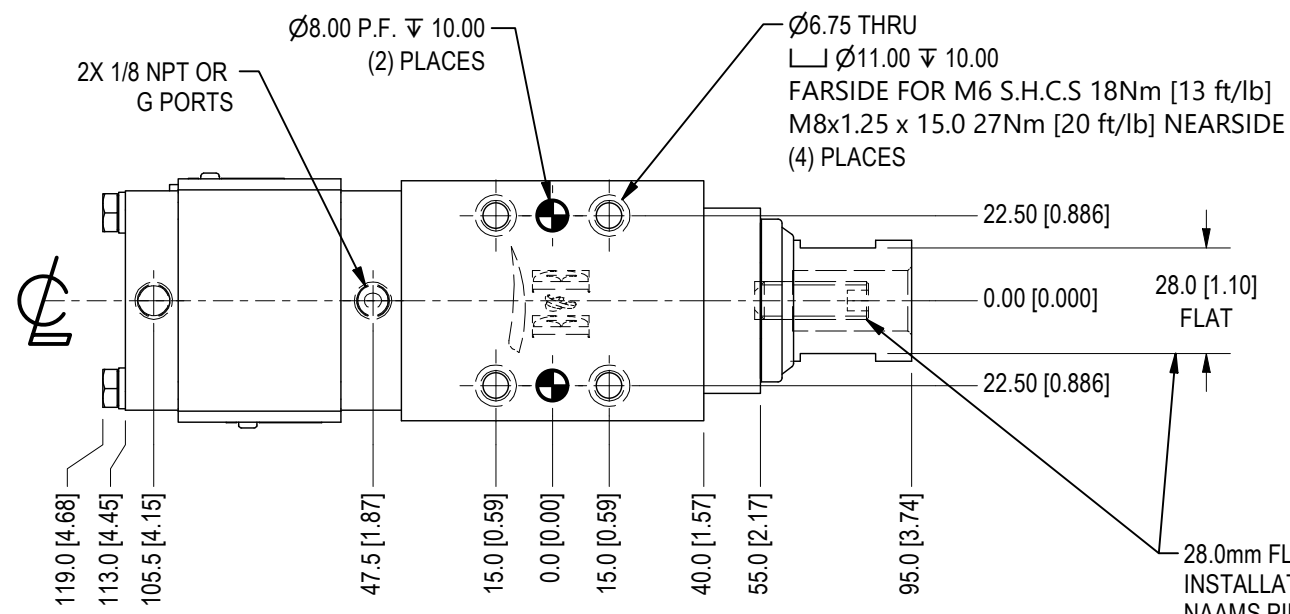

MANUAL OPTION

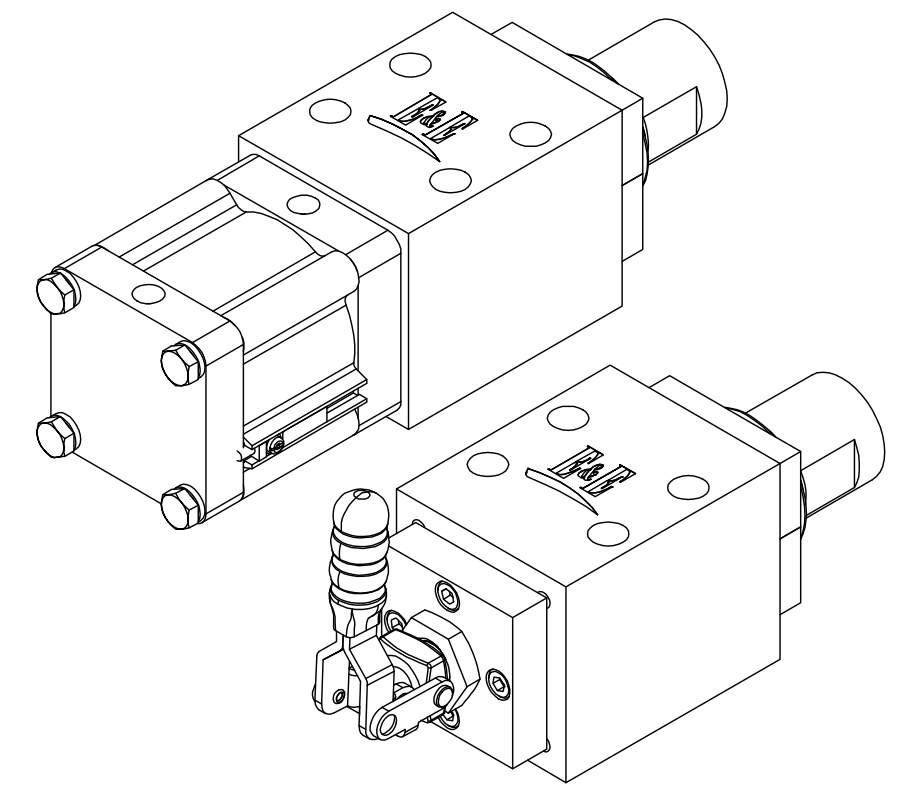

NOTE: LOAD PART RIGID (CYLINDER EXTENDED OR MANUALLY CLAMPED) UNLOAD PART FLOATING (CYLINDER RETRACTED OR MANUALLY UNCLAMPED)  
 OPERATING PRESSURE = 60 psi MIN - 120psi MAX WEIGHT = 4.5lbs [2.04kg]

<p>E &amp; E CUSTOM PRODUCTS</p> <p>7200 MILLER DR. WARREN, MI 48092 EE-CP.COM</p>	<p>NOTICE: THIS DRAWING IS PROPERTY OF E&amp;E CUSTOM PRODUCTS INCLUDING THE PRINCIPLES OF THE DESIGN INVOLVED, AND IS SUBMITTED WITH AGREEMENT THAT IT IS NOT TO BE REPRODUCED, COPIED, OR LOANED, IN PART OR WHOLE, ACCEPTANCE OF THIS DRAWING WILL BE CONSTRUED AS AN AGREEMENT TO THE ABOVE</p>		
	<p>TITLE 50mm BORE PNEUMATIC OR MANUAL FLOAT PIN</p>		
	<p>PART NO.</p>		
	<p>DRAWN BY:</p>	<p>CHK'D BY: EC</p>	<p>APPR'D BY: MH</p>
	<p>DATE: 4/23/2019</p>	<p>DATE: 10/19/2023</p>	<p>DATE: 10/19/2023</p>
<p>SCALE: 1/2</p>	<p>DWG. NO. AFP TEMPLATE</p>		
<p>SHT 1 OF 1</p>			