

**ORDERING INFORMATION**

SYM	CHANGES	DATE	BY
-----	---------	------	----

ASP24- [ ] [ ] N D 0 8 C 0 9 E S [ ] [ ] [ ] [ ] [ ] [ ] E 0

- Stroke**  
100 & 125
- Actuator**  
N Pneumatic - G Ports
- Ram Dowels**  
D08 (Dowels are Nominal)
- Ram Holes**  
C09 Clearance holes
- Switch**  
E Efector Weld Immune
- Switch Position**  
E S01 Ext Pos
- Ram Position**  
0 0 Degree (Shown)  
9 90 Degree
- Port Position**  
1 Port Position (Shown)  
2 Port Position  
3 Pi Port Position  
4 Port Position
- Shield**  
S None

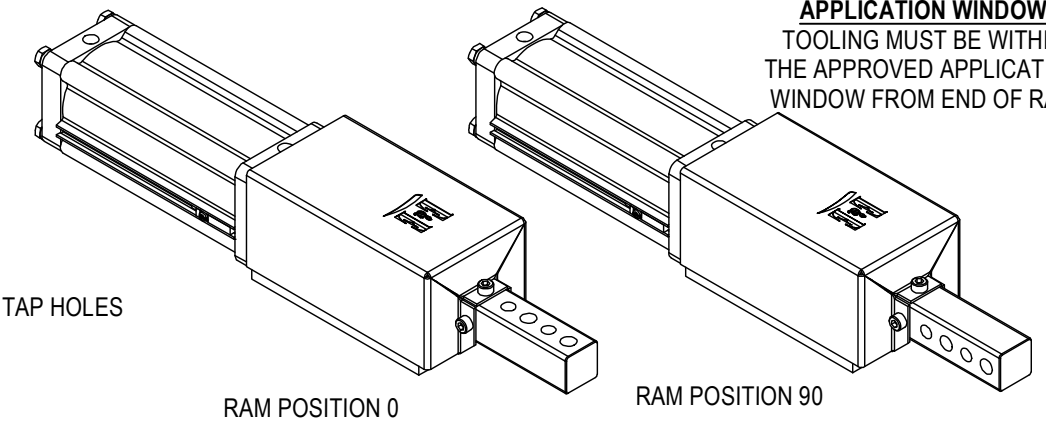
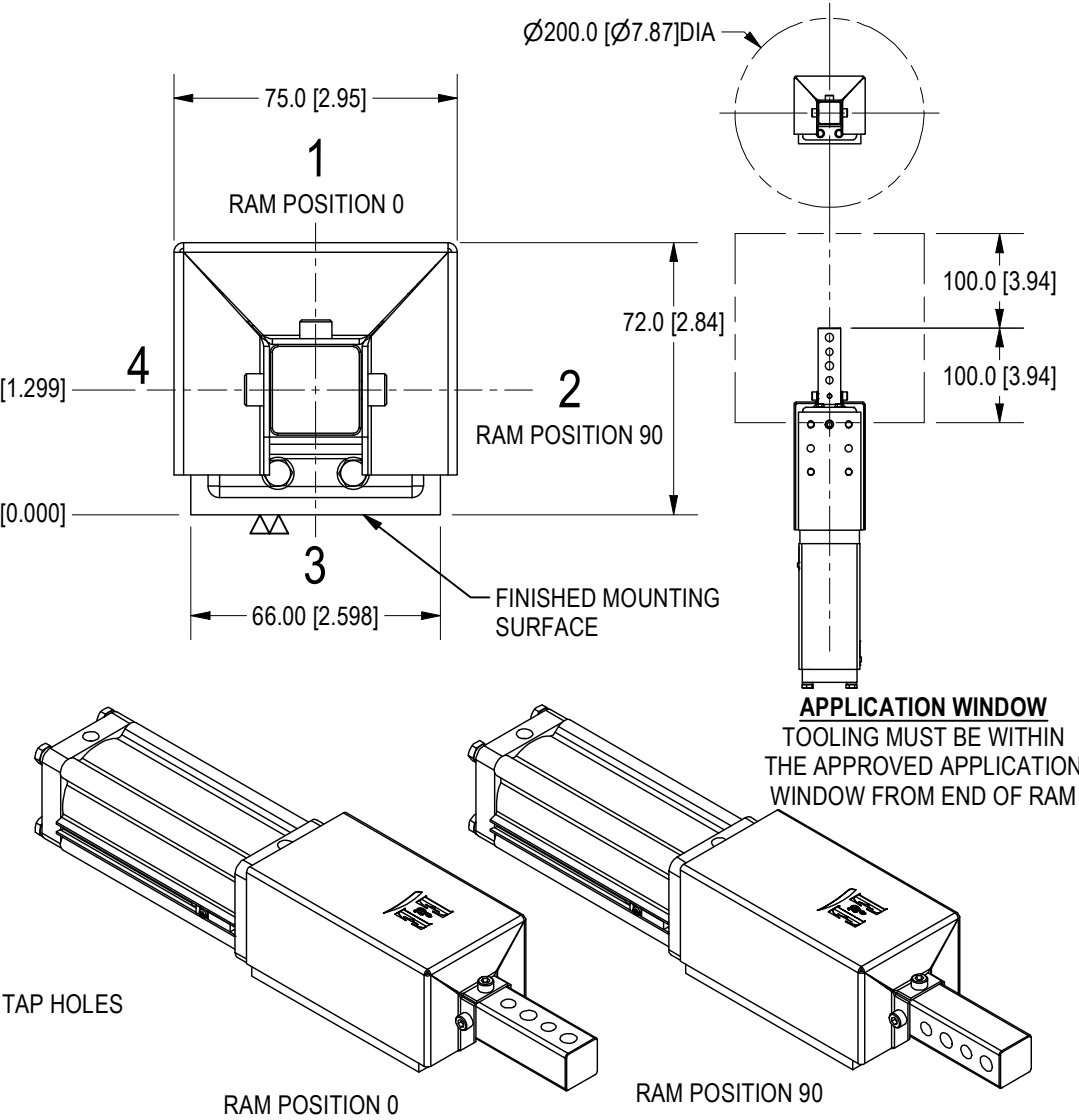
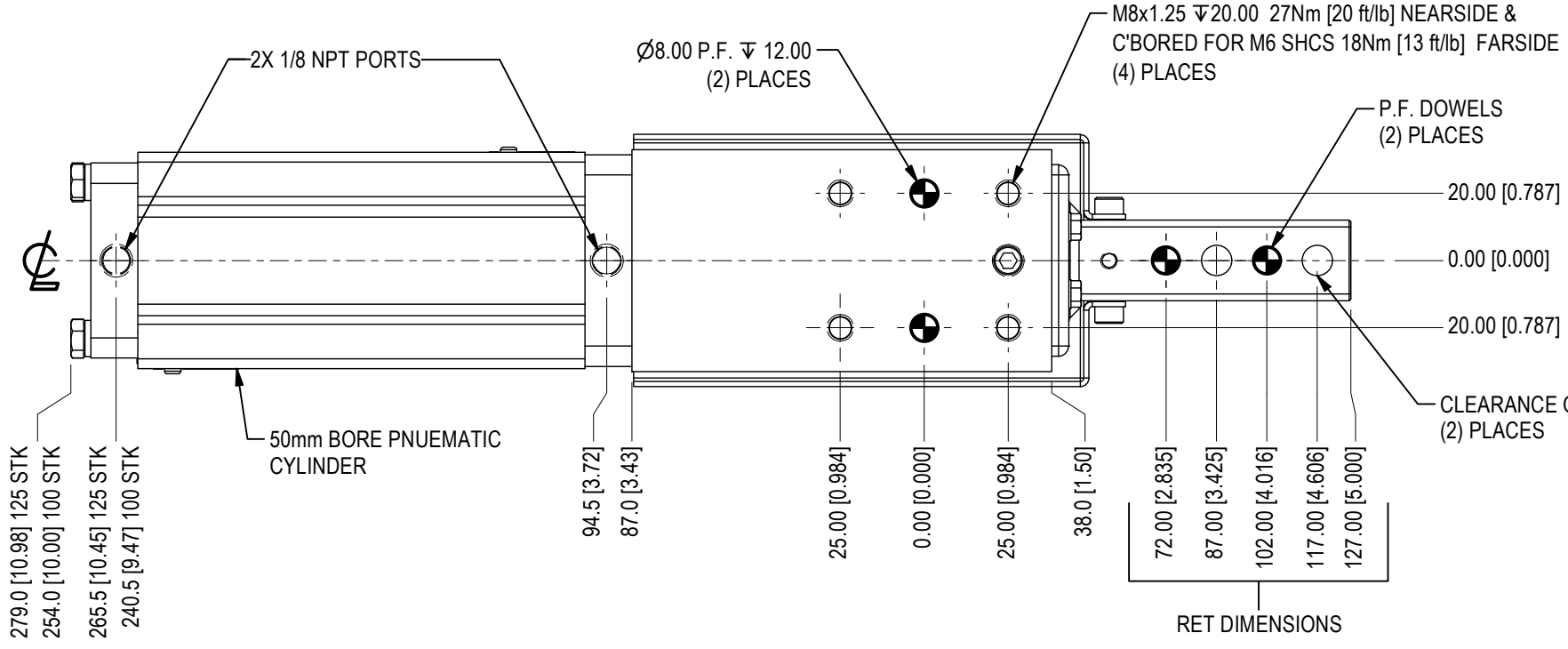
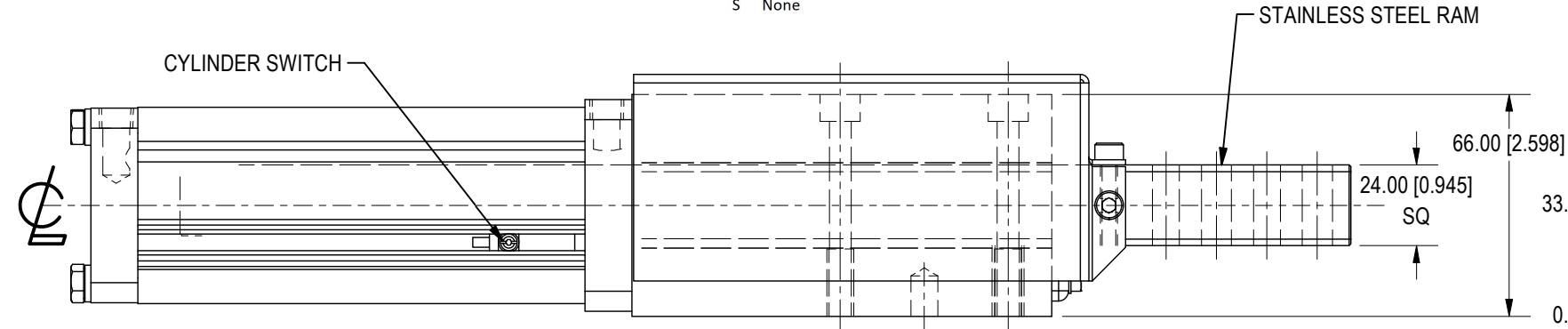

OPERATING PRESSURE - MIN 60psi = 182lbf [82.5kgf] EXT FORCE - 169lbf [76.6kgf] RETRACT FORCE  
 MAX 120psi = 362lbf [164.2kgf] EXT FORCE - 338.5lbf [153.5kgf] RETRACT FORCE  
 LOAD RATING - MAX TOOLING WT=22.5lbs [10kg], MAX GEO CONTACT OFFSET IS 100mm. MAX SIDE LOAD IS 55lbs [25kg]

WEIGHTS =  
 8.5lbs for 100mm Stroke  
 9.0lbs for 125mm Stroke

 7200 MILLER DR. WARREN, MI 48092 EE-CP.COM	NOTICE: THIS DRAWING IS PROPERTY OF E&E CUSTOM PRODUCTS INCLUDING THE PRINCIPLES OF THE DESIGN INVOLVED, AND IS SUBMITTED WITH AGREEMENT THAT IT IS NOT TO BE REPRODUCED, COPIED, OR LOANED, IN PART OR WHOLE, ACCEPTANCE OF THIS DRAWING WILL BE CONSTRUED AS AN AGREEMENT TO THE ABOVE		
	TITLE 24 SERIES LONG STROKE SHOT PIN		
	PART NO.		
	DRAWN BY: EE	CHK'D BY: EC	APPR'D BY: MH
DATE: 9/14/2022	DATE: 10/18/2023	DATE: 10/18/2023	
SCALE: 1/2	DWG. NO.		
SHT 1 OF 1	ASP24-Long Stroke Template - QMC Standard		