

SYM	CHANGES	DATE	BY
-----	---------	------	----

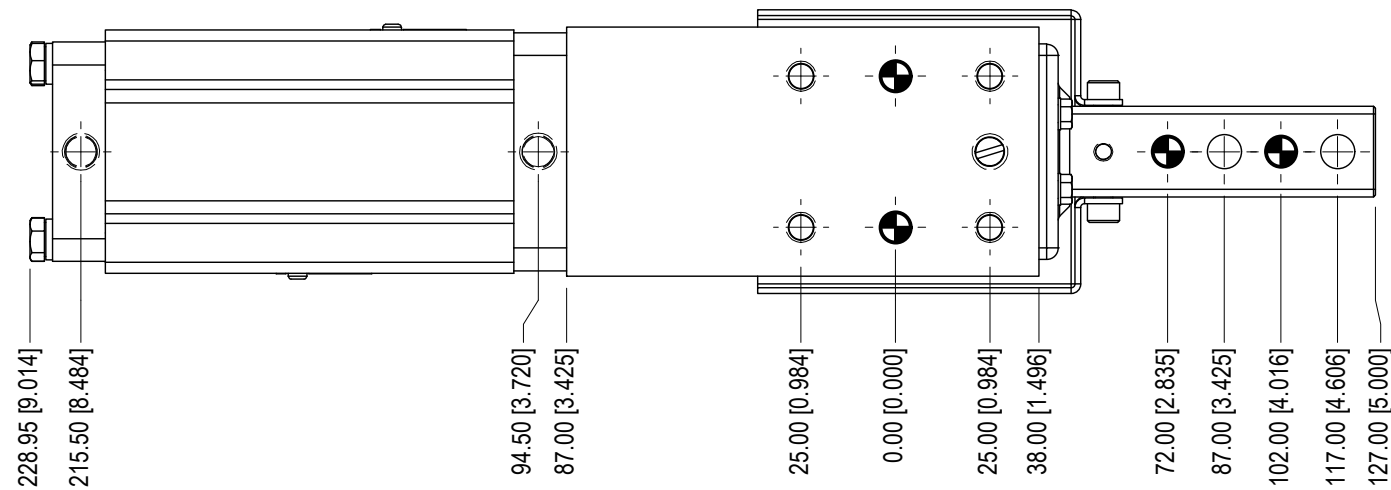
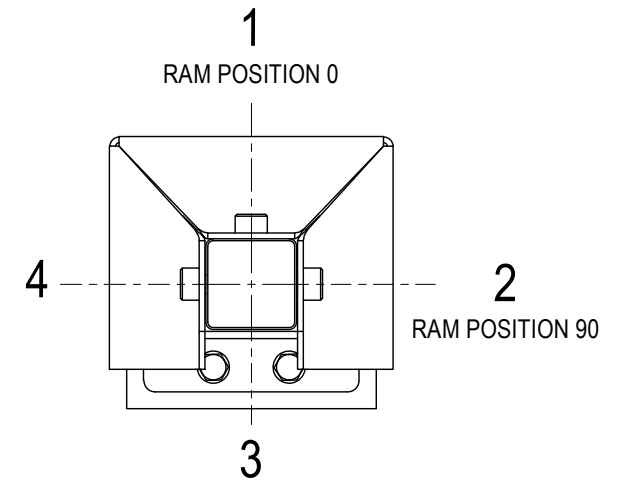
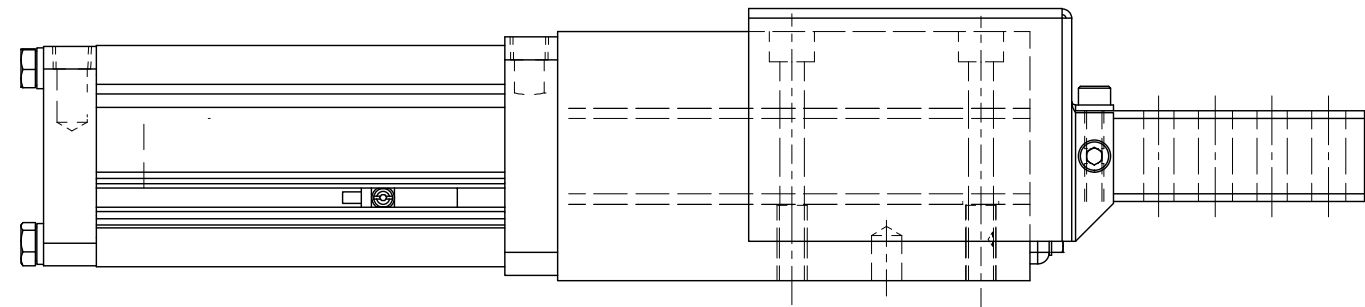

THIS SHEET IS FOR 75mm STROKE DETENT OPTION ONLY

	<small>NOTICE: THIS DRAWING IS PROPERTY OF E&E CUSTOM PRODUCTS INCLUDING THE PRINCIPLES OF THE DESIGN INVOLVED, AND IS SUBMITTED WITH AGREEMENT THAT IT IS NOT TO BE REPRODUCED, COPIED, OR LOANED, IN PART OR WHOLE, ACCEPTANCE OF THIS DRAWING WILL BE CONSTRUED AS AN AGREEMENT TO THE ABOVE</small>		
	TITLE 24 SERIES SHOT PIN		
	PART NO.		
	DRAWN BY:	CHK'D BY: EC	APPR'D BY: TT
7200 MILLER DR. WARREN, MI 48092 EE-CP.COM	DATE: 10/18/2023 SCALE: 1/2 SHT 2 OF 2	DATE: 10/18/2023 DWG. NO. ASP24-Template-FLEXCAN / P207	