

SYM

CHANGES

DATE

BY

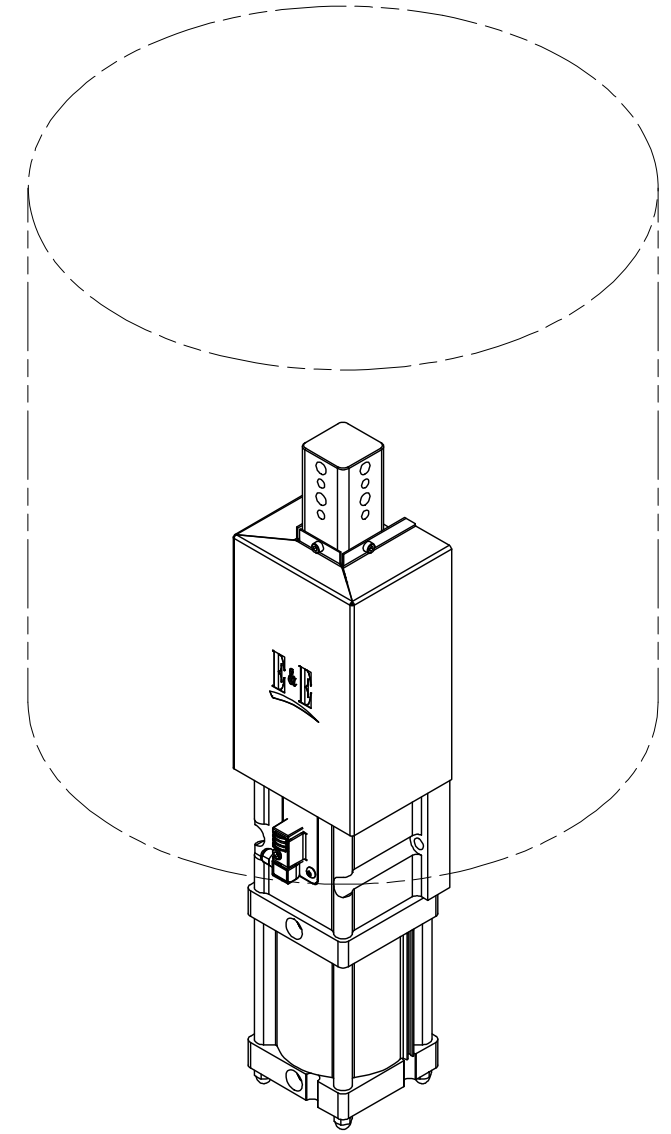
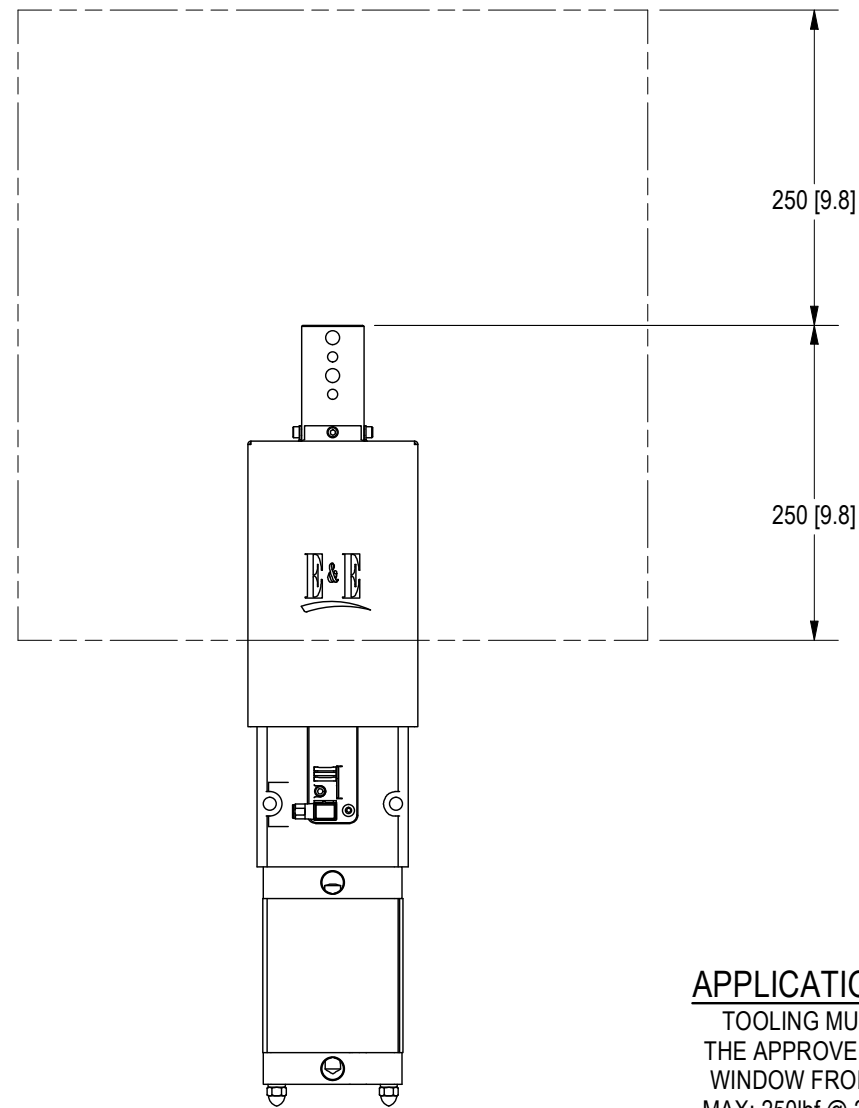
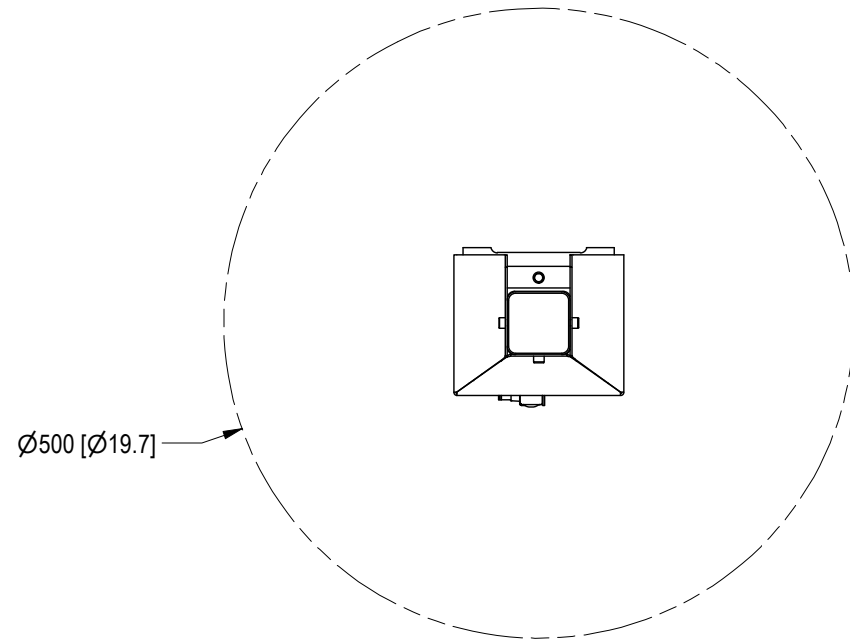

APPLICATION WINDOW

TOOLING MUST BE WITHIN THE APPROVED APPLICATION WINDOW FROM END OF RAM
MAX: 250lbf @ 250.00mm [9.84"]

	<small>NOTICE: THIS DRAWING IS PROPERTY OF E&E CUSTOM PRODUCTS INCLUDING THE PRINCIPLES OF THE DESIGN INVOLVED, AND IS SUBMITTED WITH AGREEMENT THAT IT IS NOT TO BE REPRODUCED, COPIED, OR LOANED, IN PART OR WHOLE, ACCEPTANCE OF THIS DRAWING WILL BE CONSTRUED AS AN AGREEMENT TO THE ABOVE</small>		
	TITLE 50 SERIES SHOT PIN		
PART NO.			
DRAWN BY: EE	CHK'D BY: EC	APPR'D BY: MH	
DATE: 3/21/2023	DATE: 10/23/2023	DATE: 10/23/2023	
SCALE: 1/6	DWG. NO. ASP50-TEMPLATE-GESTAMP		
SHT 2 OF 2			
7200 MILLER DR. WARREN, MI 48092 EE-CP.COM			