

SYM	CHANGES	DATE	BY
-----	---------	------	----

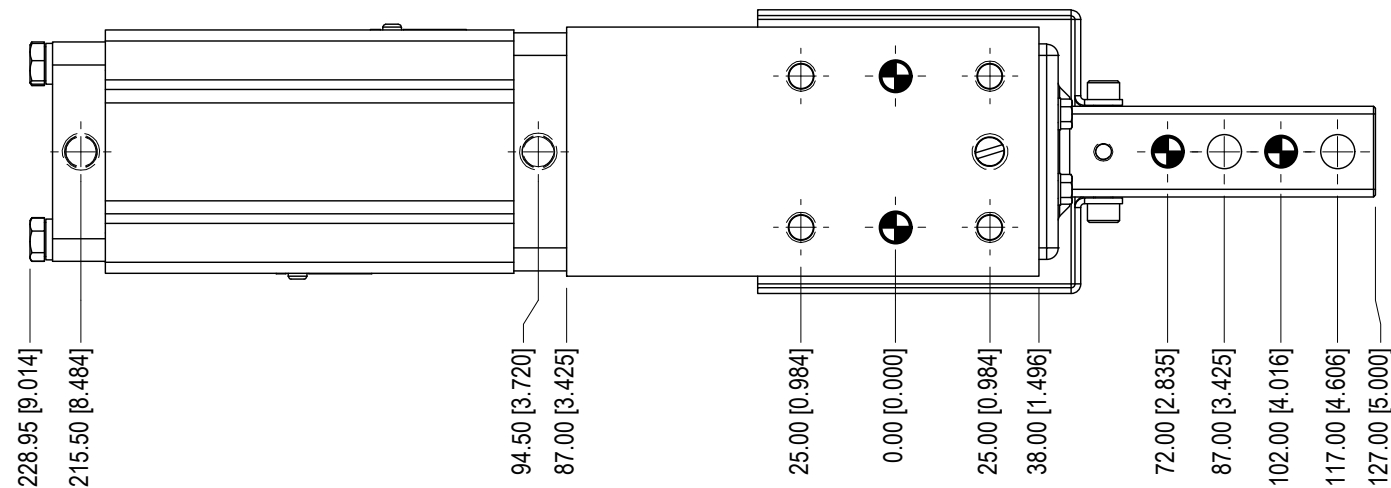
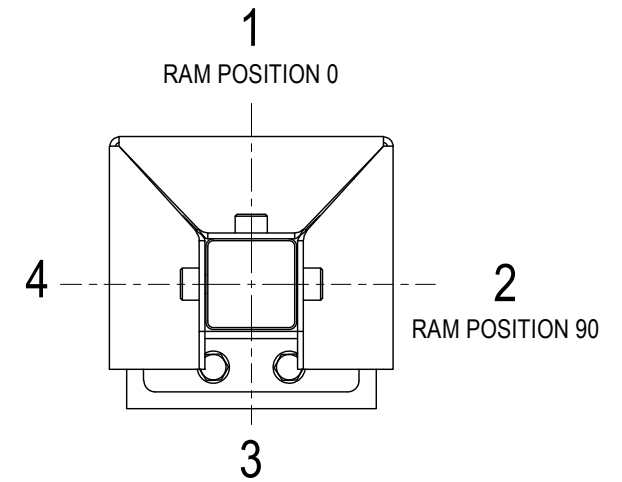
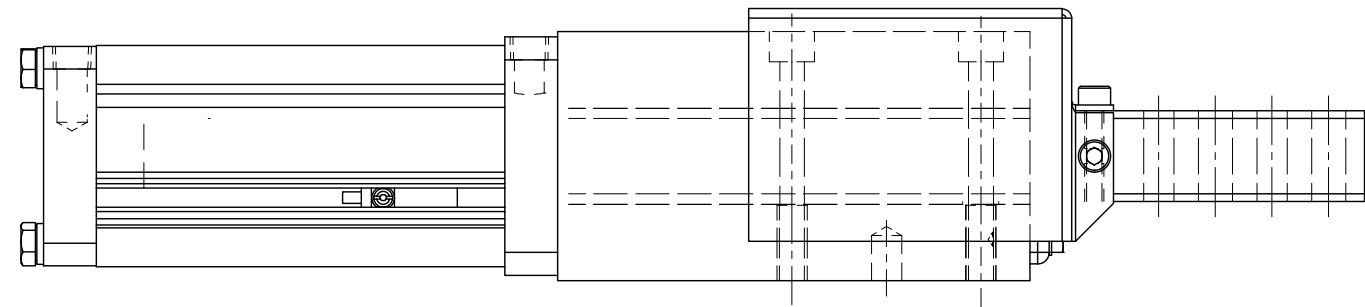

SPARE PARTS AND MAINTENANCE KIT

CYLINDER KIT P/N: ASP24-CK

INCLUDES:

- (2) ASP24 CYLINDER BUMPER SEALS
- (1) METRIC PISTON SEAL
- (1) ASP24 DOUBLE LIP SEAL

WIPER KIT P/N: ASP24-WK

INCLUDES:

- (1) ASP24 SS SCRAPER
- (1) ASP24 DOUBLE LIP WIPER
- (4) SELF TAPPING SCREWS

MIG & ARC SHIELD KIT P/N: ASP24-MAS

INCLUDES:

- (1) ASP24 SHIELD
- (3) M5X0.8-8 SHCS

THIS SHEET IS FOR 75mm STROKE DETENT OPTION ONLY

 E & E CUSTOM PRODUCTS	<small>NOTICE: THIS DRAWING IS PROPERTY OF E&E CUSTOM PRODUCTS INCLUDING THE PRINCIPLES OF THE DESIGN INVOLVED, AND IS SUBMITTED WITH AGREEMENT THAT IT IS NOT TO BE REPRODUCED, COPIED, OR LOANED, IN PART OR WHOLE, ACCEPTANCE OF THIS DRAWING WILL BE CONSTRUED AS AN AGREEMENT TO THE ABOVE</small>		
	TITLE 24 SERIES SHOT PIN		
	PART NO.		
	DRAWN BY:	CHK'D BY: EC	APPR'D BY: TT
7200 MILLER DR. WARREN, MI 48092 EE-CP.COM	DATE: 10/18/2023 SCALE: 1/2 SHT 2 OF 2	DATE: 10/18/2023 DWG. NO. ASP24 TEMPLATE	